

Original Operating Manual

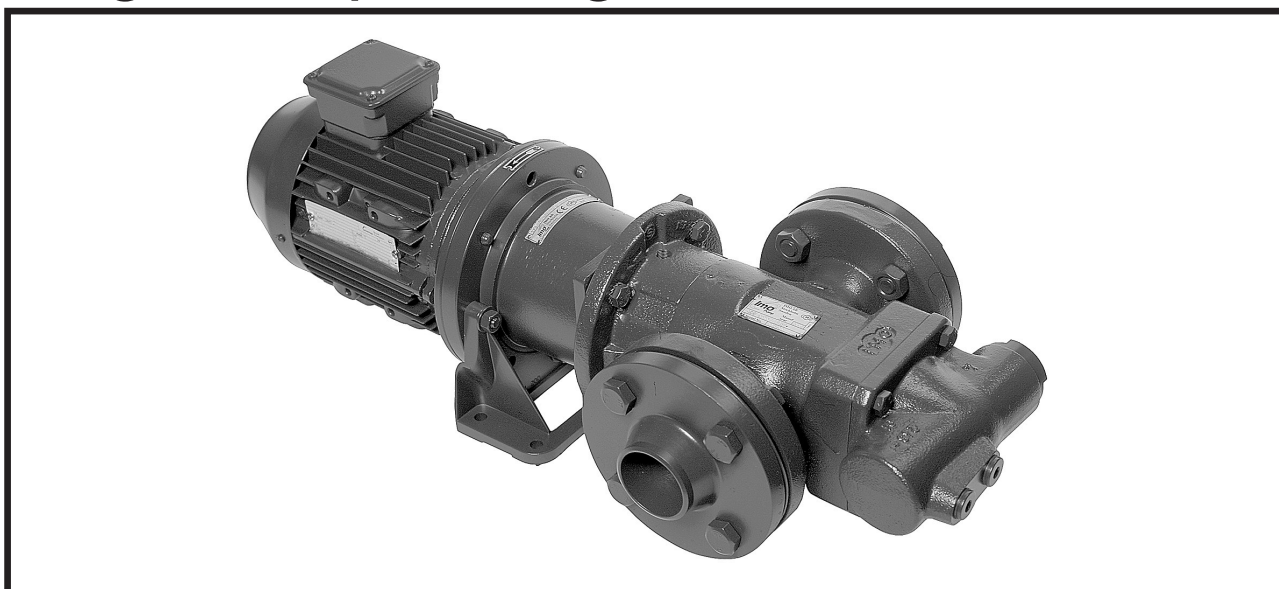

Contents	Page
Introduction	2
Safety	2
Pump identification	4
Installation	5
Start-up	10
Trouble shooting	12
Maintenance and Service	14
List of components	14
Exploded View/Ordering code	15
Service intervals/Shaft seal-assembly drawing/ Service for ball bearing	16
Lubricating intervals in working hours/Useful tools	17
Sectional View	18
Dismantling	19
Reassembly	21
Pressure relief valve	23



Before commencing any work, read this instruction carefully! Failure to comply with these instructions may cause damage and personal injury!

Introduction

Other applicable documents

Order data sheet	Technical specifications, conditions of operation
Technical description	Technical specifications, operating limits
Supplier documentation	Technical documentation for parts supplied by subcontractors, e.g. drive system, coupling or auxiliary operating system.
Spare parts list	Ordering spare parts
Declaration of conformity	Conformity with standards, Content of the declaration of conformity

Safety

ATTENTION

The manufacturer accepts no liability for damages caused by disregarding any of the documentation.

Intended use

- Only use the pump to pump the agreed pumped liquids (→ order data sheet).
- Adhere to the operating limits.
- Avoid dry running:
 - Make sure the pump is only operated with, and never without, pumped liquid.
- Avoid cavitation:
 - Open the pressure-side fitting completely.
- Avoid damage to the motor:
 - Do not switch on the motor more than the maximum permissible number of times per hour (→ manufacturer's specifications).
- Consult the manufacturer about any other use of the pump.
- Pumps delivered without a motor must be assembled into a pump unit according to the provisions of EC Machine Directive 2006/42/EC.

Prevention of obvious misuse (examples)

- Note the operating limits of the pump with regard to temperature, pressure, viscosity, flow rate and motor speed (→ order data sheet).
- When using auxiliary systems, ensure there is a continuous supply of the appropriate operating medium.
- Do not operate the pump while the pressure-side fitting is closed.
- Only select the setup type according to this operating manual. For example, the following are not allowed:
 - Hanging pumps in the pipe
 - Overhead installation
 - Installation in the immediate vicinity of extreme heat or cold sources

General safety instructions

ATTENTION

Observe the following regulations before carrying out any work.

Product safety

The pump has been constructed according to the latest technology and recognized technical safety rules. Nevertheless, operation of the pump can still put the life and health of the user or third parties at risk or damage the pump or other property.

- Only operate the pump if it is in perfect technical condition and only use it as intended, remaining aware of safety and risks, and adhere to the instructions in this manual.

- Keep this manual and all other applicable documents complete, legible and accessible to personnel at all times.
- Refrain from any procedures and actions that would pose a risk to personnel or third parties.
- In the event of any safety-relevant malfunctions, shut down the pump immediately and have the malfunction corrected by the personnel responsible.
- In addition to the entire documentation for the product, comply with statutory or other safety and accident-prevention regulations and the applicable standards and guidelines in the country where the system is operated.

Obligations of the operating company

Safety-conscious operation

- Ensure that the following safety aspects are observed and monitored:
 - Intended use
 - Statutory or other safety and accident-prevention regulations
 - Safety regulations governing the handling of hazardous substances
 - Applicable standards and guidelines in the country where the pump is operated
- Make personal protective equipment available.

Qualified personnel

- Make sure all personnel tasked with work on the pump have read and understood this manual and all other applicable documents, especially the safety, maintenance and repair information, before they start any work.
- Organize responsibilities, areas of competence and the supervision of personnel.
- Ensure that all work is carried out by specialist technicians only:
 - Fitting, repair and maintenance work
 - Work on the electrical system
- Make sure that trainee personnel only work on the pump under the supervision of specialist technicians.

Safety equipment

- Provide the following safety equipment and verify its functionality:
 - For hot, cold and moving parts: on-site safety guards for the pump
 - For possible electrostatic charges: provide the necessary grounding
 - If there is no pressure relief valve in the pump: Provide an appropriate safety valve on the pressure side between the pump and the first shut-off device

Warranty

- Obtain the manufacturer's approval prior to carrying out any modifications, repairs or alterations during the warranty period.
- Only use genuine parts or parts that have been approved by the manufacturer.

Drive system

For pumps delivered without a drive system, comply with the following requirements for the drive system:

- When using three-phase asynchronous motors, observe IEC 60034-30-1.
- Power of the drive according to EN ISO 5199 is recommended (EN ISO 5199 also applicable for drives of screw pumps).
- For stub shaft coupled pumps (LPD and ACD) connect motor and stub shaft directly.
- For other series use elastic coupling according to DIN 740-2.
- Use coupling guard with the following requirements:
 - Fastening elements must be connected to the pump unit in undetachable design (cannot get lost).
 - Safety distances against the reaching of hazardous areas according to EN ISO 13857 must be complied with.

Obligations of the operating company

- All directions given on the pump must be followed (and kept legible), e.g. the arrow indicating the sense of rotation and the markings for fluid connections.
- Pump, coupling guard and components:
 - Do not step on them or use as a climbing aid
 - Do not use them to support boards, ramps or beams
 - Do not use them as a fixing point for winches or supports
 - Do not use them for storing paper or similar materials
 - Do not use hot pump or motor components as a heating point
 - Do not de-ice using gas burners or similar tools
- Do not remove the safety guards for hot, cold or moving parts during operation.
- Use personal protective equipment whenever necessary.
- Only carry out work on the pump while it is not running.
- Isolate the motor from its supply voltage and secure it against being switched back on again when carrying out any fitting or maintenance work.
- Reinstall the safety equipment on the pump as required by regulations after any work on the pump.







Specific hazards

Hazardous pumped liquids

- Observe the safety regulations for handling hazardous substances (e.g. hot, flammable, poisonous or potentially harmful) when handling hazardous pumped liquids.
- Use personal protective equipment when carrying out any work on the pump.
- Noise level:
 - Check individual pump series noise level in respective Product Description

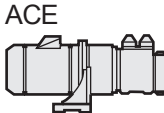
These instructions are valid for all low pressure pumps as specified in the Pump identification chart below.

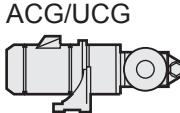
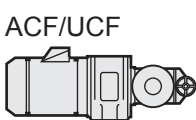
Pump identification

Pump name	Size (1)	Rotor lead (1)	Design modification	Material pump-body (1)	Shaft-seal design (1)	Mounting (2)	Valve (3)	Also valid for option	Comments
LPD 	015 } 020 }	N	1	I	V	B	P		Pumpunit without shaft coupling
ACD 	025	L } N }	6	N	V } T }	B	P		Pumpunit without shaft coupling
ACE 	025 } 032 } 038 }	D } K } L } N }	3	N	V } T }	B	P	A101	
LPE 	025 } 032 } 038 }	D } K } L } N }	3	N	V } T }	B } Y }	P	A101	
ACG/UCG 	045 } 052 } 060 } 070 }	D } K } N }	7	N	V } T }	B } F }	E } P }	A101 A327 A020 A385	
ACF/UCF 	080 } 090 } 100 } 110 } 125 }	K } L } N }	5	I } N }	T	B } F ⁽⁴⁾ }	E ⁽⁴⁾ } P }	A020 A084 A087 A101	
LPQ 	100 } 110 } 125 } 140 }	L } N } P } J }	1	I } N }	R } T }	Y	P		

Option

- (1) See Product description or Service instruction for specified pump model
- (2) B = Flange mounting
F = Foot mounting
Y = Vertical foot mounting
- (3) E = Without valve
G = Valve with external return
P = Valve with internal return for total pressure range
- (4) Valid for UCF

- A020 Pump with surface treated casing(s)
 A084 Pump with lifetime greased ball bearing
 A087 Pump with CCW-rotation and lifetime greased ballbearing
 A101 Pump with CCW-rotation, when not standard
 A327 Pump with Tuning®
 A328 Pump with Tuning®
 A385 A101 + A327

Identification of safety instructions

Non compliance of safety instructions identified by the following symbol - could affect safety for persons.



Safety instructions where electrical safety is involved, are identified by:



Safety instructions which shall be considered for reasons of safe operation of the pump or pump unit and/or protection of the pump or pump unit itself are marked by the sign:

ATTENTION

Installation

BEFORE COMMENCING ANY WORK, READ THIS INSTRUCTION CAREFULLY!

Design limitations and technical data for each pump are found in the **Product description**.

Installation of IMO AB low pressure pumps does not require special skills. However, these instructions presume that the work is carried out by experienced fitters.

Maintenance and service instructions, which are specific for each pump are presented after the installation instructions.



Failure to comply with these instructions may cause damage and personal injury!

Transport and storage

Always protect the pump against ingress of water and other impurities. Store the pump in a clean, dry and warm environment. The pump is delivered with the internals oiled and with protective covers over the pipe connections and drain openings. These covers should remain in place for as long as possible during the mounting and installation procedure but must be removed before start up.



All work carried out on the pump has to be performed in such a manner that risks for personal injury are observed!

Lifting of pump



All pumps should be lifted with straps securely attached to the pump or pump unit, so that the center of gravity is located between the straps in order to avoid tipping of the pump.

Use two eye bolts (M 20) securely fastened to the front cover for pump LPQ. Pump and connecting frame are lifted together using two eye bolts securely fastened to the top of the connecting frame. (Thread dimension is M 16, except for frame size 600, where it is M 20).

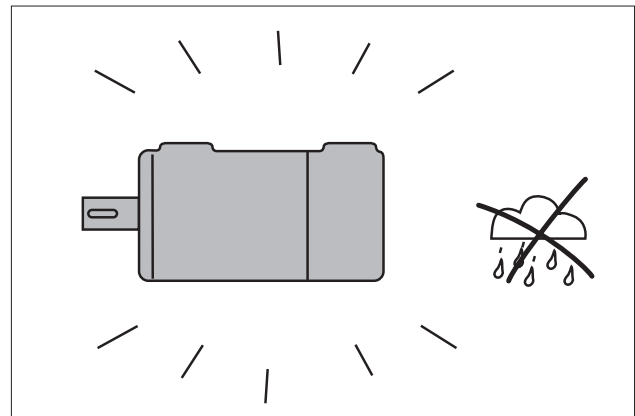

Fig. 1 Clean and dry environment.

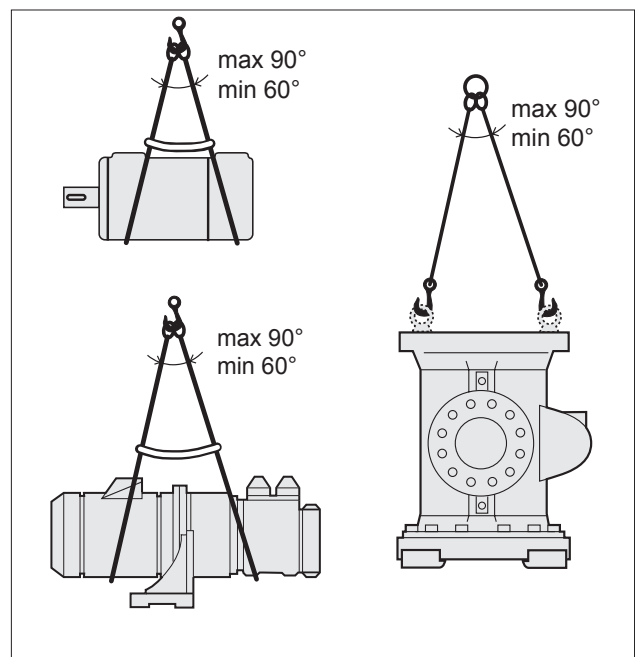

Fig. 2 Lifting of pump

Lifting of the complete pump unit with the lifting device attached to the motor, should be avoided as the motor's lifting provisions may not be able to carry the combined weight of the pump and motor.

! Lifting a complete pump unit, using slings or hooks attached to the pump or connecting frame may be dangerous since the centre of gravity of the pump unit may be higher than the points of attachments.

Mounting

The pump must be securely mounted on a firm stable foundation and positioned so that it is easily accessible for inspection and servicing.

Provisions for collecting oil spillage when servicing the pump should be considered.

ATTENTION

The installation must always be designed to minimise damage. Should an operational or functional failure occur. E.g. precautions should be considered to collect oil spillage due to a broken pipe or pump housing, to stop pump operation if overheating should occur or if the oil volume is below a minimum tank level.

Alignment and shaft couplings

The pump shall be connected to its driver via a flexible shaft coupling. Pumps of type ACG/UCG and ACF/UCF may also be driven via gears or pulleys as specified in the Product Description, provided the radial forces are kept within the specified range.

An angular misalignment of 0.1° corresponds to approx. 0.2 mm deviation/100 mm.

The coupling and alignment shall be selected not to transmit any axial or radial loads on the shaft ends. IMO AB standard couplings shall have a distance between the coupling halves as per table, fig 4. the coupling halves shall be secured by lock screws.

For other types of couplings, please refer to respective maker's manual.

! When fitting the shaft coupling, do not use a hammer or similar as this may damage the ball bearing and shaft seal. Use some kind of press tool.

! When handling liquids that may harm skin use gloves and/or protective clothing.

! When handling liquids which may involve fire hazards appropriate precautions to avoid danger are to be taken.

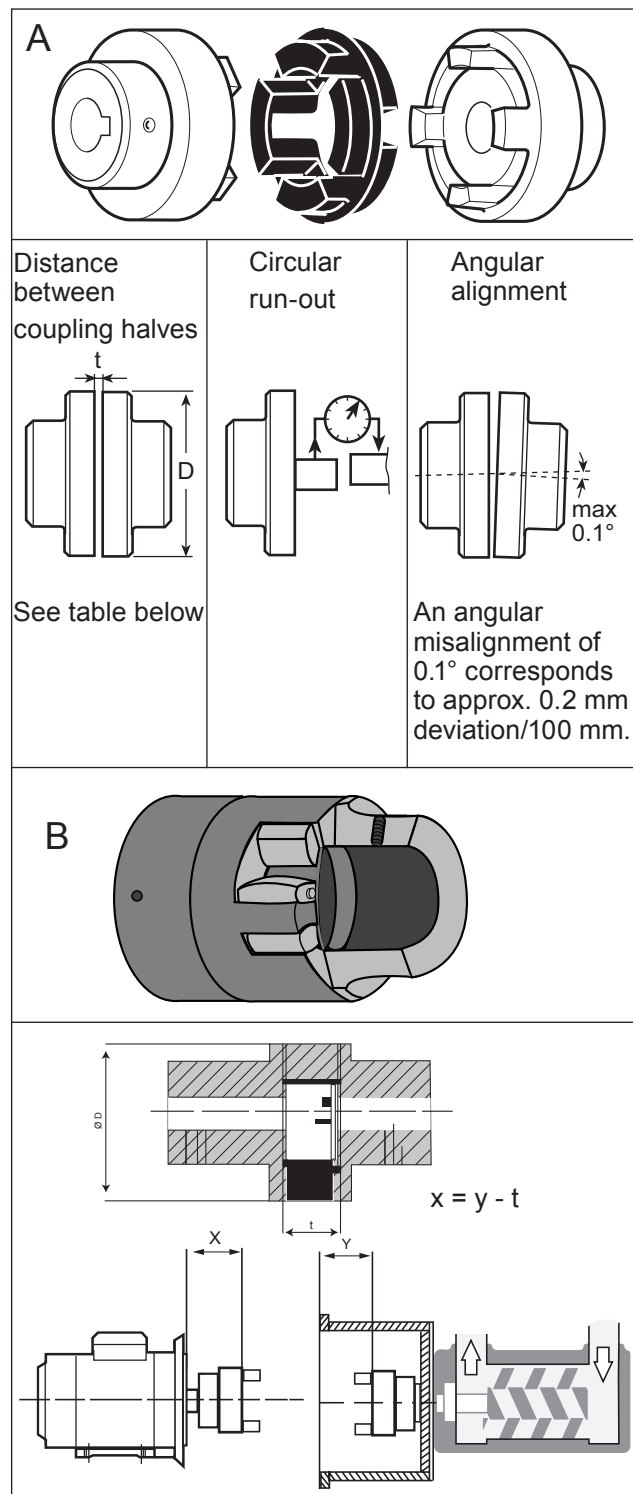

Fig. 3 Alignment of the IMO AB standard coupling

Outer diameter of coupling (D mm)(t mm)		Distance between coupling halves (D mm)		Outer diameter of coupling (t mm)	Distance between coupling halves
A	B	A	B		
50	26	2.0	8	148	3.5
67	40	2.5	16	168	3.5
82	55	3.0	18	194	3.5
97	65	3.0	20	214	4.0
112	80	3.5	24	240	4.0
128	95	3.5	26		

Fig 4. Distance between coupling halves. (IMO AB standard coupling)

⚠ Measures shall be provided to avoid accidental contact with the rotating shaft coupling. Any installed coupling guard shall permit easy access to the pump shaft for maintenance and inspection of the pump bearing and seal housing.

Pipe connections

The pipe work shall be installed and supported so that no pipe stresses are transferred to the pump body.

The pipe work should be tight in order to avoid leakage and infiltration of foreign particles and/or air.

Shut off valves should be installed in both suction and discharge pipes, so that the pump can be hydraulically isolated.

Suction line

The suction pipe should be designed so that the total pressure drop, measured at the pump inlet flange, does not exceed the suction capability of the pump.

Make a proper calculation of the suction line including components such as valves, strainer, pipe bends etc. Generally, the pressure drop in the suction line should be as low as possible, which is achieved if the suction pipe is short, straight and has a suitable diameter.

The velocity in the suction line should be kept in the range 0.5 - 1.2 m/s. For L.O. circulating systems, we recommend to keep it as low as possible.

The suction line must be equipped with a port that allows filling the pump before start.

Discharge line

The discharge line should be dimensioned to keep the velocity in the range 1 - 3 m/s.

Deaeration

In installations with negative suction head, where the pump might be started against a pressurized system, a deaeration pipe with an orifice (2-3 mm recommended) has to be installed. The deaeration pipe should be connected to the outlet pipe's highest point.

This must also be installed when the pump is used as an stand-by pump.

For direct driven pumps the alignment between pump and motor shafts must be kept within the following limits:

	Max run-out (mm)	Max angular misalignment (degrees)
Type LPD and ACD	(n/a short coupled)	
Other types	0.3	0.1

Fig 5.

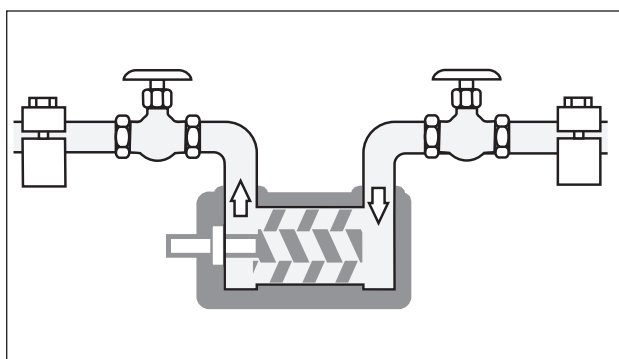

Fig. 6 Pipe connections

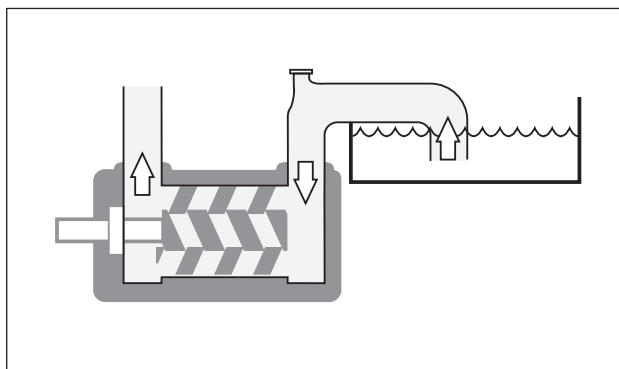

Fig.7 Suction line

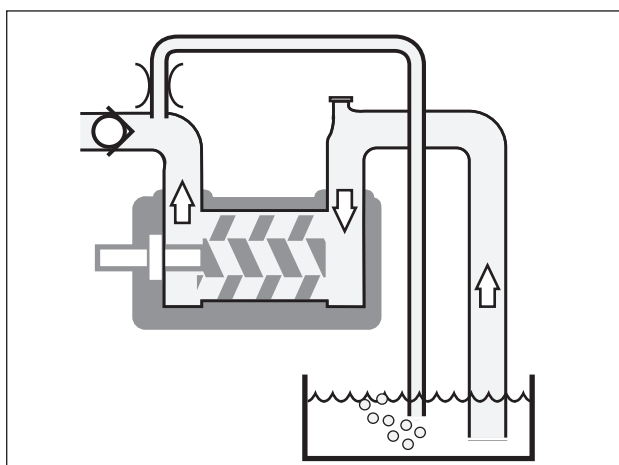

Fig. 8 Deaeration

Strainer

The pump has to be protected from foreign matter, such as weld slag, pipe scale, etc., that could enter the pump via the suction line. If the cleanliness of the system cannot be guaranteed, a strainer must be installed in the inlet pipe near the pump. For practical reasons a suction strainer with 0.6 mm mesh openings is recommended:

The size of the strainer should be selected so that it is large enough to allow adequate pressure at the pump inlet. The pressure drop across the strainer should preferably not exceed 0.1 bar at max. flow rate and normal operating viscosity. A vacuum gauge between the strainer and the pump inlet is recommended to indicate when the strainer needs cleaning.

Note: The service life of the pump is decisively influenced by the degree of contamination of the fluid being conveyed, that means, by the number, size and hardness of the abrasive components.

Shaft seal drain

The pump should be installed so that any leakage from the shaft seal does not become a hazard. As the shaft seal has to be lubricated a small amount of oil dripping cannot be avoided.

Provisions to collect the leakage from the shaft seal must be made.

A drain pipe can be connected to the drain connection on the pump, (not applicable to pump series LPD). However, when pumping heavy fuel oil or any other liquid that is likely to become very viscous at ambient temperature, we recommend that the liquid is allowed to drop freely from the drain opening.

Liquid trap

In some mounting arrangements the pump may not retain the liquid at stand still. In such installations the suction pipe should be arranged so it forms a liquid trap together with the pump, keeping the pump half filled with liquid. See fig. 11.

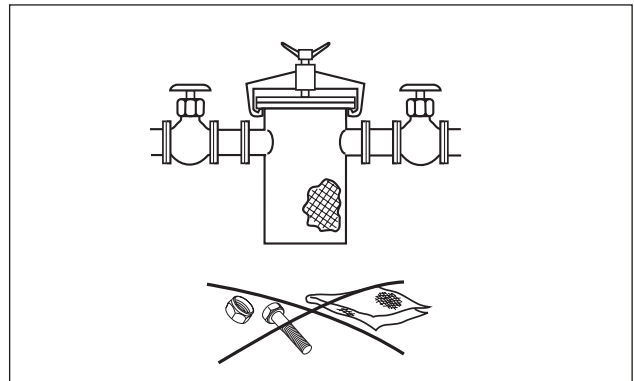

Fig. 9 Strainer

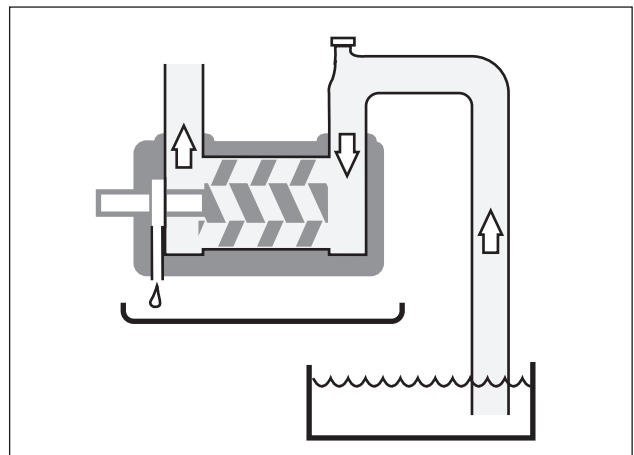

Fig. 10 Shaft seal drain

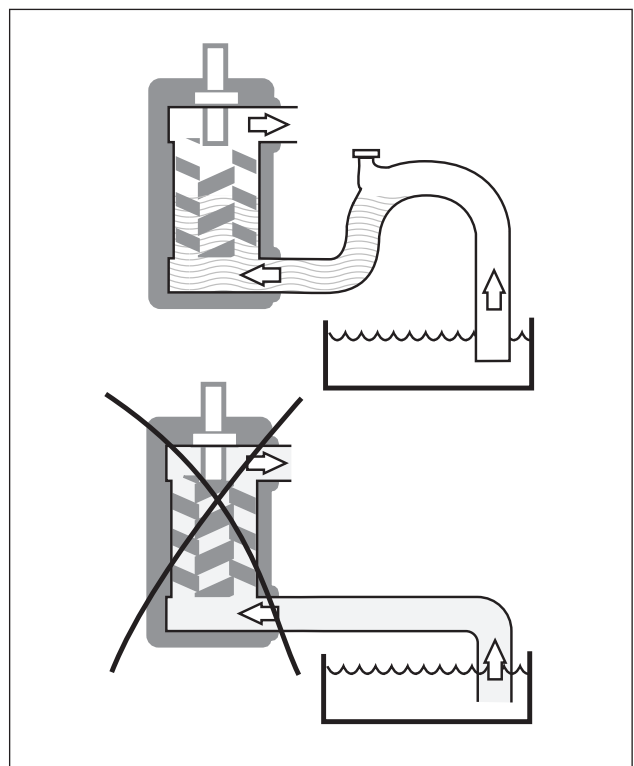

Fig. 11 Liquid trap

Gauges

Gauges for monitoring the pump's working conditions are recommended. These gauges should be placed readable as close to the pump's in- and outlet flanges as possible. On standard pumps, series ACE, LPE, ACG/UCG, ACF/UCF and LPQ, there are gauge connections for both in- and outlet.

Pressure relief valve

All systems with screw pumps should be equipped with a pressure relief valve installed immediately adjacent to the pump.

In the standard versions of IMO AB low pressure pumps, this pressure relief valve is an integral part of the pump to protect the pump against excess pressure.

This relief valve is intended for momentary protection of the pump against overpressure. It is neither intended to be a system pressure control device, nor used as a flow regulation device.

When liquid is circulated through the valve it is heated up in proportion to the set pressure level and the percentage of by-passed liquid.

Up to 50 % by-pass can generally pass for unlimited periods of time without harming the pump except when pumping low viscosity media.

If more than 50% recirculation is anticipated, a value specific to each application should be determined by closely monitoring the pump body temperature.

For flow less than $\sim 50 \text{ m}^3/\text{h}$

- 100% by-pass can only be tolerated for less than about 3 minutes, provided the viscosity & temperature is within the limit of the pump type.

For flow higher than $\sim 50 \text{ m}^3/\text{h}$

- 100% by-pass is tolerated less than 30 seconds.

Note that an open valve can cause noise.

If the pump is operating in line with a separate pressure control valve (see fig. 14), the setting of the relief valve should be high enough to not to interfere with the control valve.

Likewise, if two pumps are operating in parallel, the setting should be such that interference between the two valves is avoided.

Pressure testing and flushing

The system must be flushed and pressure tested before connecting the pump. If corrosive liquid, such as water is used, the system must be thoroughly drained, dried and protected against corrosion after having been flushed.

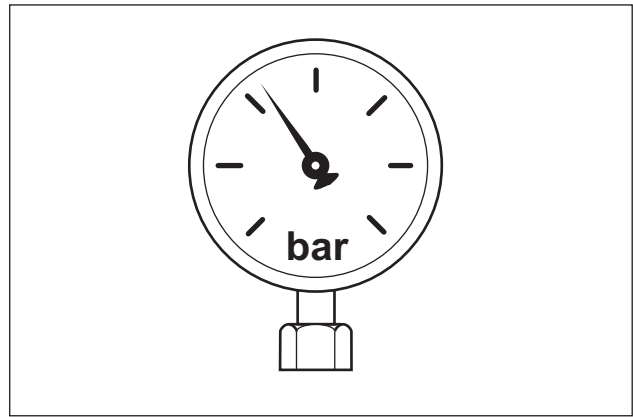

Fig. 12 Gauges

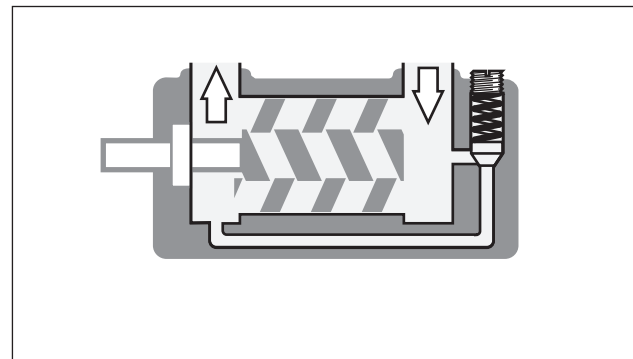

Fig. 13 Pressure relief valve

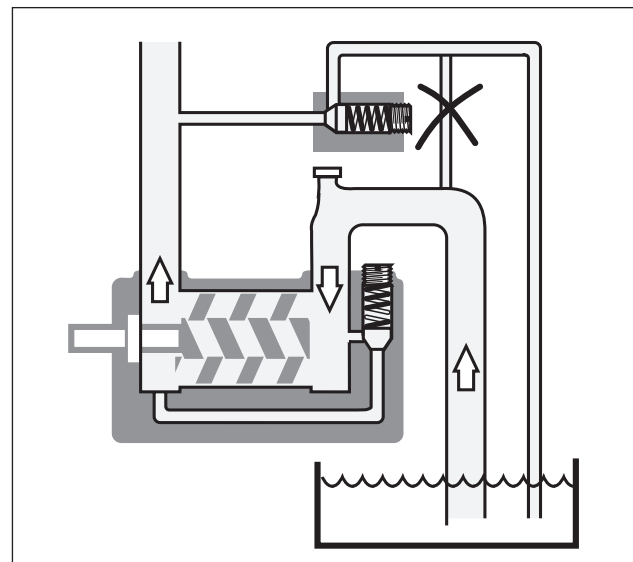

Fig. 14 External control with pressure relief valve



Oil leakage may make the floor slippery and cause personal injury.

Start-up

Before starting

After installation and whenever it can be assumed that the pump has been emptied, the pump must be thoroughly filled with liquid. See fig 15.

For ACE Generation 3, LPE Generation 3, ACG Generation 7 and ACF Generation 4 delivered after 1997, ACF Generation 5 and LPQ the pumps have been fitted with deaeration plugs making venting of the shaft seal compartment easy before start-up.

In installations with positive suction pressure: After opening the inlet and outlet valves, simply open the deaeration plug a few turns until oil sips out. Tighten the plug.

In installation with negative suction pressure: After opening the inlet and outlet valves, remove the deaeration plug and fill the shaft seal compartment with oil. Fit and tighten the plug. See fig. 16.

Note: for LPQ the amount of oil is appr 50 liter.

⚠ Make sure the prime mover is locked out and can not be started accidentally.

Rotate the shaft by hand while filling the pump, to ensure that the rotor bores and the shaft seal cavity is filled. On the smaller pumps: (LPD, ACD, ACE, LPE, ACG/UCG), this is done by rotating the fan on the electric motor after removing the fan cover.

⚠ Do not forget to fit the motor fan cover again before making start of motor possible.

On the ACF/UCF and LPQ pumps, the pump can be turned using the shaft coupling. If the suction pipe cannot be completely filled, it is important to ensure that the trapped air is evacuated without any pressure build up. (See fig. 8 Deaeration).

ATTENTION

Starting a dry pump is likely to cause damage, especially to the shaft seal.

Direction of rotation

When the pump is ready to be started, switch the motor briefly on and off and check that the drive motor rotates in the correct direction as indicated by the rotation arrow.

The arrow is placed on different spots depending on the pump series.

ATTENTION

Don't mix up with arrow for inlet and outlet!

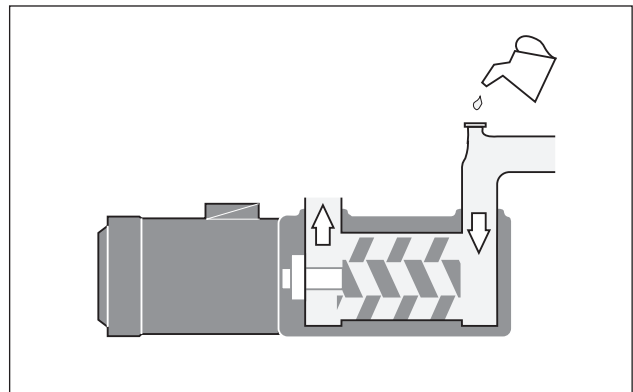

Fig. 15 Filling the pump

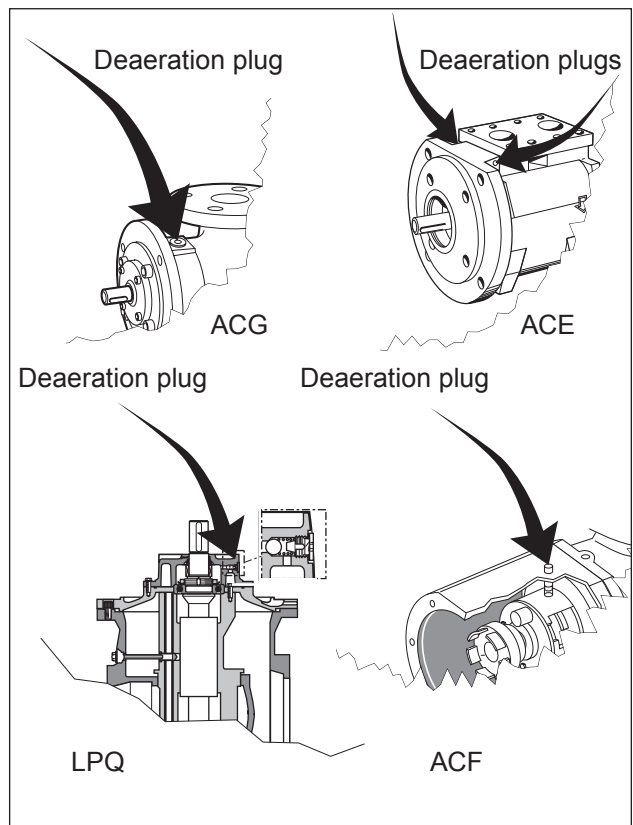

Fig. 16 Deaeration plugs

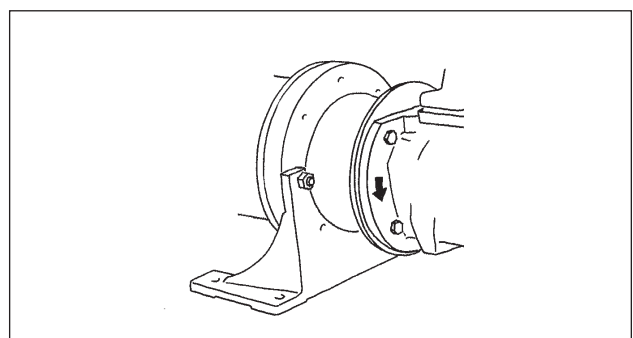

Fig. 17 Direction of rotation

Starting

Check that all valves necessary for the operation are fully opened in both discharge and suction lines.

The first time, the pump should be started with the adjusting spindle of the pressure relief valve tightened to half of the available turns (the valve setting is increased when the spindle is turned clockwise).

By monitoring the pressure gauge it can be determined when the suction line is primed and the pump begins to work. Should the pump not operate normally soon after start, stop the pump within half a minute. Start again after about 3-5 minutes (the shaft seal must have time to cool off) and run for half a minute. This procedure may need to be repeated a couple of times if the suction line is extremely long. Should the pump still not work, it must be assumed there is a problem in the system that needs to be remedied. Check the suction line calculation on page 5 and/or see "Trouble shooting", page 10.



Pumps with external ball bearing including grease nipple, must be regreased after one hour of running, while the pump is operating

Setting the pressure relief valve

To set the opening pressure;

Tighten the valve spindle by rotating clockwise to the maximum extent. The system pressure is regulated by throttling an external valve to required value. The pressure relief valve is eased until the pressure is just beginning to decrease by turning the spindle CCW. The internal relief valve is now preset for desired opening pressure. Open the throttling external valve entirely.

As standard, the recommended valve setting is 1 bar above system pressure.

NOTE: The set screw on LPD is hidden behind a plate.

Adjusting the tuning

The tuning adjustment, which is a standard feature on ACF/UCF and LPQ (option on ACG/UCG pumps, is a device for minimizing the effects of dissolved and free air in lube oil systems. The tuning principle is described in the Product Description.

The tuning should be adjusted while the pump is working under normal operating conditions. This is done by turning the tuning spindle with an Allen key (size 8 mm for ACG/UCG , 12 mm for ACF/UCF and LPQ) to a position where the noise level comes to a minimum. On a double acting pump like the LPQ pump, there are two tuning valves, which must be adjusted individually.

Setting of tuning of the LPQ:

1. Before starting the setting check that both setting screws (8 mm socket head cap screw on the discharge side) are closed.
2. Turn the lower screw until the noise level obtains a minimum. (If turned too much the noise will increase again).
3. Turn the upper screw and continue to reduce the noise level. (If turned too much the noise will increase again).
4. Repeat item 2. and 3. in order to achieve the lowest possible noise level.

Setting of tuning of the ACG/UCG and ACF/UCF:

1. Before starting the setting, check that the setting screw (8 mm: ACG/UCG, 12 mm: ACF/UCF, socket head cap screw on the discharge side) are closed.
2. Turn the screw CCW until the noise level becomes the lowest (if turned too much the noise will increase again).

Once set, the tuning needs no further adjustment, providing the operating conditions stay the same.

NOTE: It´s not possible to accidentally turn the tuning spindle too far.



If operating temperature exceeds 60°C (149°F), appropriate measures to avoid skin contact shall be provided.



Use hearing protections whenever high noise can be expected from pump, motor and/or environment.

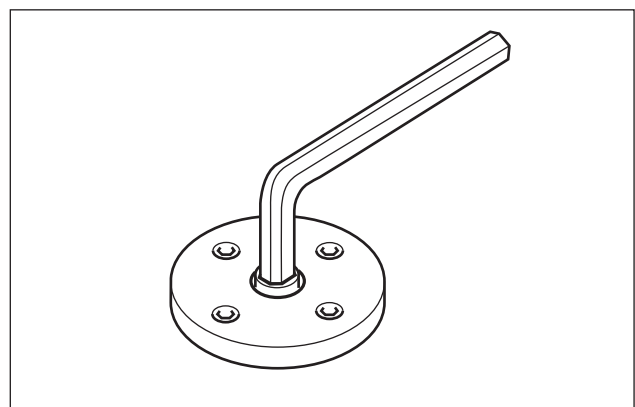



Fig. 18 Adjusting the tuning

Trouble shooting

Problem	Cause	What to do
Wrong direction of rotation	<ul style="list-style-type: none"> - Electric cables to motor wrongly connected. 	<p>Reverse the terminal connection on electric motor.</p> <div style="border: 1px solid black; padding: 5px; background-color: #f0f0f0;">  <p>Connecting and disconnecting of electric cables must be done only by personnel authorized to do such work.</p> </div>
The pump cannot be primed	<ul style="list-style-type: none"> - Wrong direction of rotation. - Suction line is not open or pressure drop in the suction line is too high. - Major air leakage into the suction line. - The pump cannot evacuate the air through the discharge line due to excessive counter pressure. 	<p>See above.</p> <p>Check all components in suction line. The inlet condition should be checked with a vacuum gauge at the pump inlet.</p> <p>Check the suction line.</p> <p>See the chapter on Deaeration (see page 5).</p>
No flow	<ul style="list-style-type: none"> - The pump is not primed. - The pressure relief valve is set below the counter pressure. 	<p>See above.</p> <p>Readjust the pressure relief valve to a value above counter pressure.</p>
Flow too low	<ul style="list-style-type: none"> - The pressure relief valve is set too low (Discharge pressure also low). - Something is restricting the flow in the suction line. (This would usually cause noise). - The pumped liquid contains a significant amount of compressible gas, such as free air. (This would usually cause noise). 	<p>Readjust the pressure relief valve.</p> <p>Check all components in the suction line (strainers, valves etc.).</p> <p>See the chapter on Noise and Vibration. (Page 11).</p>
Pressure too low	<ul style="list-style-type: none"> - The pressure relief valve is set too low. - Counter pressure in the discharge line is too low due to a major leakage. - The valve piston is stuck in open position. - Something is restricting the flow in the suction line. (This would usually cause noise). - The pumped liquid contains a significant amount of compressible gas, such as free air. (This would usually cause noise). - A too small pump has been chosen. 	<p>Readjust the pressure relief valve.</p> <p>Check the components in the discharge line inclusive the recipients.</p> <p>Check the valve. See Maintenance and Service instruction for respective pump.</p> <p>Check all components in the suction line (strainers, valves etc.).</p> <p>See the chapter on Noise and Vibration. (Page 11).</p> <p>Contact your IMO AB representative.</p>

Disturbance	Cause	What to do
<p>Pressure too high</p>	<ul style="list-style-type: none"> - The pressure relief valve is set too high. - The oil is too cold (or has higher viscosity than anticipated). - Counter pressure in the discharge line is too high. 	<p>Readjust the pressure relief valve.</p> <p>Reduce the pressure setting until operational temperature has been reached.</p> <p>Check the discharge line.</p>
<p>Drive motor difficult to start or tends to stop by tripping the motor overload relay</p>	<ul style="list-style-type: none"> - Counter pressure too high. - Liquid too cold - Motor is undersized for the prevailing conditions. - Electrical power supply faulty. - Motor overload relay set too low or is faulty. - Incorrect setting of Y/D starter. 	<p>See above: Pressure too high.</p> <p>Readjust the pressure relief valve to a lower value. Thus the power consumption for the pumping is relieved and overloading due to the high viscosity may be avoided. When the liquid has reached normal temperature and thus flows easily, the relief valve is reset to normal pressure.</p> <p>Check the motor.</p> <p>Check the motor and motor connection.</p> <p>Readjust or replace the relay.</p> <p>Readjust the setting of the starting sequence. The time before the motor overload relay is tripped should not exceed 10-15 seconds.</p>
<p>Noise and vibrations</p> <div style="border: 1px solid black; background-color: #e0e0e0; padding: 5px; margin-top: 10px;">  <p>Monitor the pump function and shut down if any sign of malfunction is noticed.</p> </div>	<ul style="list-style-type: none"> - The flow to the pump is insufficient. - Insufficient support of pipe work. - Bad alignment - Air leakage into the suction line. - Free air in the liquid or gas cavitation. - Faulty electrical supply. 	<p>See chapter: The flow is too low.</p> <p>Check for pipe vibrations in the pump connections. Check that the pipes are sufficiently clamped.</p> <p>Check alignment, see page 4.</p> <p>Check the suction line for air leakage.</p> <p>For pumps with Tuning: Adjust the Tuning. If this does not help or for pumps without Tuning: Contact your IMO representative or IMO service dept.</p> <p>Check all three phases of the supply.</p>

Maintenance and Service

List of components

Valid for all pumps in sizes: ACG/UCG 045/052/060/070; Rotor diameter and generation: K7/N7

With version codes: N } T } B } E }
 V } V } F } P }
 G }

Also valid for pump options: A101, A327, A385
 Example of pump designations
 std: ACG 045N7 NVBP; option ACG 070N7 NVBP A101

PosNo	Denomination	Qty	Components included in Spare parts sets:						Note
			G011	G012	G050	G053	G054	G057	
1010	Power rotor CCW-rot.	1	x				(x)		
1020	Power rotor CW-rot.	1		x			x		
106	Balancing piston	1	x	x			x		5
113	Shaft key	1	x	x			x		
120	Distance sleeve	1							
122	Ball bearing	1				x	x		
124	Retaining ring	1				x	x	x	
124A	Support ring	1				x	x	x	
201	Idler rotor CCW-rot.	2	x				(x)		
202	Idler rotor CW-rot.	2		x			x		
359	Distance washer	1							
359A	Support ring	1				x	x	x	
401	Pump body	1							
424	Sleeve	1							4
424A	Washer	1							4
429	Spindle	1							4
437	O-ring	1							4
440	Return valve	1							8
451	Screw	4/6							
453	Screw	4							
462	Plug	2							1
462A	Sealing washer	2				x	x	x	1
473	Grease nipple	1							
473A	Grease nipple cover	1							
480	Valve housing	1							2
5010	Front cover	1							
502	Tension pin	1							6
502A	Plug	1							6
506	Gasket	1				x	x	x	
509	Shaft seal	1			x	x	x		
514	Retaining ring	1				x	x	x	
537	Plug	2							
537A	Sealing washer	2				x	x	x	
551	Rear cover	1							3
556	Gasket	1				x	x	x	
601	Valve cover	1						x	2,7
602	Sealing washer	1				x	x	x	2
605	O-ring	1				x	x	x	2
608	Valve spindle	1						x	2,7
608A	Retaining ring	1				x	x	x	2
612	Set screw	1						x	2,7
614	Valve piston	1						x	2,7
615	Valve spring	1						x	2

Explanations:
 G011: Rotor set
 CCW-rotation option
 G012: Rotor set
 CW-rotation (std)
 G050: Shaft seal
 G053: Minor kit
 (G050 + G057) + 122
 G054: Major kit consisting
 of: G053+G012 (G011)
 G057: Joint kit
 G070: Valve element
 ACG Pump with DIN
 flanges
 UCG Pump with ANSI
 flanges
 A101: CCW
 A327: With Tuning
 A385: CCW and Tuning

Notes:
 1) Excluded in xxxG
 2) Excluded in xxxE
 3) Valid for xxxE
 4) Valid for pump option
 A327
 5) Included in item 1020
 or 1010
 6) Included in item 5010
 7) Only sold as G070
 8) Removed from August 2011

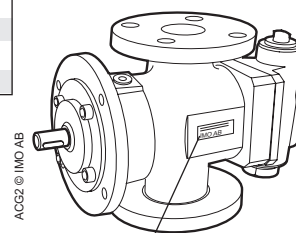

Name plate of the pump

Exploded view

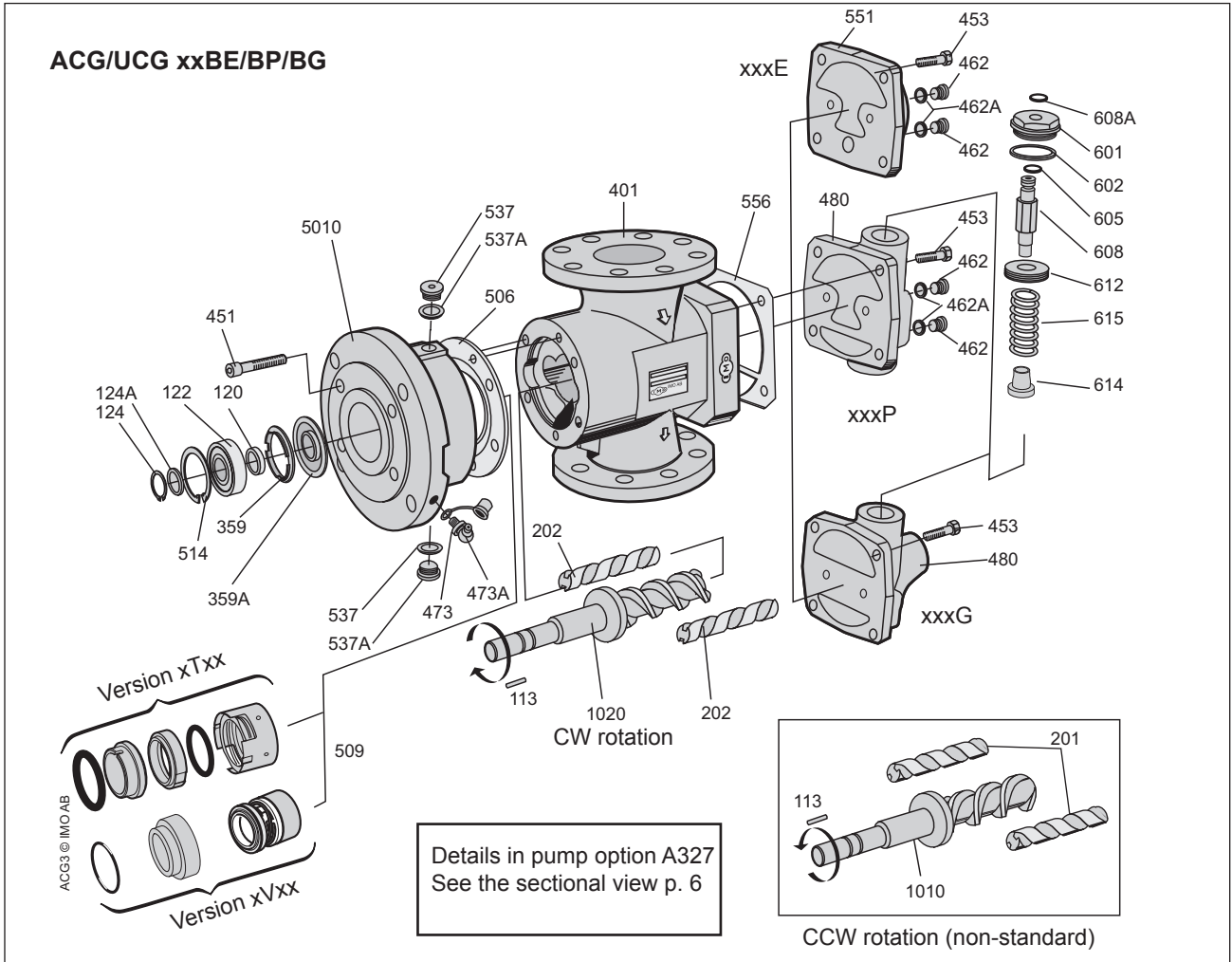

Fig. 1

Ordering code

Pos No	Spare parts sets	Part numbers, sizes			
		045	052	060	070
G012	Rotor set CW-rotation (std): Normal lead - pump version N7 Low lead - pump version K7	178913	179507	179515	179523
"		187542	187559	187567	187575
G011	Rotor set CCW-rotation (non-std): Normal lead - version N7 Low lead - version K7	186478	186486	186494	186502
"		189641	189642	189643	189644
G050	Complete shaft seal - version code xVxx " - version code xTxx	190335 174094	190336 174102	190338 174110	190340 174128
G053	Minor kit - version code xVxx " - version code xTxx	191241 191242	191243 191244	191245 191246	191247 191248
G054	Major kit=G012(G011)+G053	-	-	-	-
G057	Joint kit	191237	191238	191239	191240
G070	Valve element - version code xxxP/G	191250	191250	191251	191251
122	Ballbearing	078576	077461	191181	191182

Recommendation:
For maintenance the following spare part sets are recommended:
Set: To be used:
G057 Joint kit
For dismantling of the pump

G053 Minor kit
For service

G054 Major kit
For repair after damage or greater wear.

Ordering example:
For IMO-pump ACG 045N7 NVBP, serial number 456789
Shaft seal
pos G050 p/n 190335
Ballbearing
pos 122 p/n 078576

Fig. 2

Service intervals

The intervals for inspection and replacement of wear parts vary greatly with the properties of the pumped liquid and can only be determined by experience.

All internal parts of the ACG-pump are lubricated by the pumped liquid. Pumping liquid which contains abrasive materials, or liquid that is corrosive, will significantly reduce service life and call for shorter service intervals.

Wear in the pump may be indicated by:

- Vibration
- Noise
- Loss of capacity
- Reduction in flow/pressure
- Leakage

In installations where unplanned shut downs must be avoided, it is advisable to have a complete pump available for replacement, should any malfunction occur. Furthermore we recommend planned inspection and overhaul at regular intervals, not exceeding 3 years.

It is recommended always to have the spares included in minor spare part kit available.



All work carried out on the pump has to be performed in such a manner that risks for personal injury are observed!

Inspection of shaft seal

As the seal faces of a mechanical shaft seal are lubricated by the fluid a certain leakage will always be present. Ten drops per hour can be considered as acceptable.

An external visual inspection of the pump is advisable at least every two days to assure that the shaft seal is not leaking too much.

Excessively leaking shaft seals should be changed without delay, as the leakage normally will grow worse and cause additional damage.

Follow the instructions in the dismantling/reassembly session.

When working with a shaft seal, cleanliness is of utmost importance. Avoid touching the seal faces. If necessary, the seal faces should be cleaned immediately prior to assembly, using a dustfree cloth and clean solvent.

Never use grease on the seal faces.



Connecting and disconnecting of electric cables must be done only by personnel authorized to do such work.



If the pumps operating temperature exceeds 60°C let the pump cool off before any service, maintenance or dismantling work is commenced to avoid burn injury.

Shaft seal - assembly drawing

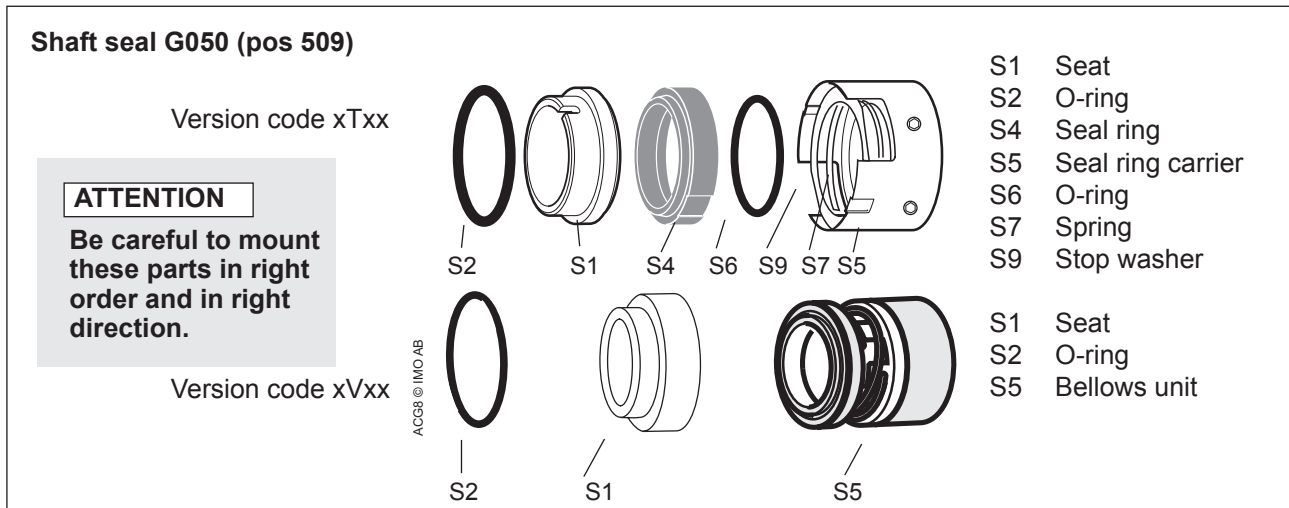

Fig. 3

Service for ball bearing

The ACG-pump is fitted with an external grease lubricated ball bearing.

When delivered from IMO AB, the ball bearings in pump version xVxx are filled with grease of type B. For version xTxx, type C is used.

Whenever the ball bearing is removed, it is recommended to exchange it for a new one.

Fit the new ball bearing properly greased and re-grease it after one hour of running, while the pump is operating.

Use an appropriate type of grease, as per table and a grease gun suitable for grease nipple (pos 473) according to DIN 71 412 (ISO 6392).

On vertical mounted units the greasing intervals are reduced to half.

Installed in dusty or dirty premises or in a corrosive environment it should be lubricated at more frequent intervals.

If using others than these recommended greases check if it is possible to mix them with each other, otherwise clean before using a new grease.

Lubricating intervals in working hours

Temp max °C	Grease type	Pump sizes 045 and 052						Pump sizes 060 and 070					
		Speed, r/min						Speed, r/min					
		3500*	2900	1750	1450	1150	950	3500*	2900	1750	1450	1150	950
70	A	8500	10000	10000	10000	10000	10000	7500	8500	10000	10000	10000	10000
90	A	3350	3950	5350	5950	6350	7500	2950	3350	4750	5150	5950	6750
110	B	2650	3150	4250	4700	5000	5950	2350	2650	3750	4100	4700	5350
130	B	1050	1250	1650	1850	2000	2350	900	1050	1500	1600	1850	2100
155	C	650	750	1050	1150	1250	1500	600	650	950	1000	1150	1300

*) at rotation speed > 3 500 r/min special instructions are given by IMO AB.

Recommended greases (the availability of the greases can differ locally):

Type A: BP Energrease LS 3, Esso Beacon 2, Mobilgrease HP 222, Shell Alvania G3, Texaco Multifak EP2, SKF LGMT2,

Q8 REMBRANDT EP2, CASTROL APS2, ELF ROLEXA 3, TOTAL MULTIS TIR EP3, FINA MARSON L3.

Type B: BP Energrease LC2, CHEVRON SRI GREASE 2, Esso Unirex N3, Mobilith SHC220, SHELL RETINAX LX, SHELL Albida LX, VAL-PLEX EP GREASE, Texaco Hytex EP2, SKF LGHQ 3, Q8 RUBENS, CASTROL LMX, INDUSTRIAL GREASE HEAVY, TOTAL MULTIS THT2, FINA PLUTON L2.

Type C: Mobilith SHC 460

Pump size	045	052	060	070
Grease amount (g)	4	6	7	9



When handling liquids which may involve fire hazards appropriate precautions to avoid danger are to be taken.



Before any maintenance work, ensure that the driver is deenergized and the pump hydraulically isolated.



In case of failure for a system with elevated pressure, fluid jets may cause injury and/or damage.

Useful tools

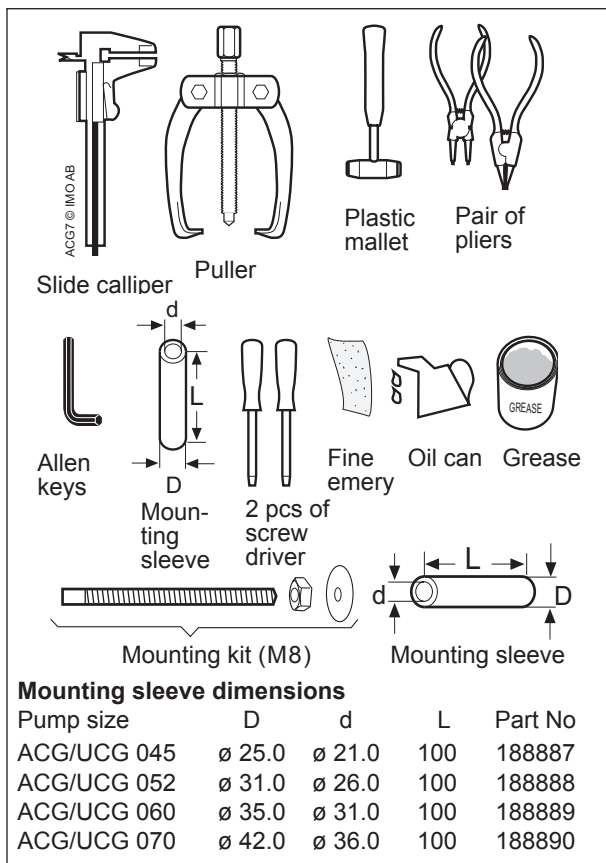

Fig. 4

Inspection of rotors

If an indication of a worn pump is noticed (see service intervals above), a brief inspection of the idler rotors is recommended.

A quick inspection of the idler rotors can be made simply by removing the rear cover or valve cover. Note that the driver must be deenergized and the pump hydraulically isolated before the rear cover is removed. Provisions to handle the fluid are to be made. If a more thorough investigation is needed, proceed as under "Dismantling".

Internal clearances in the pump, which are vital for its proper function, may have been affected by wear. Acceptable wear can be determined only by experience of the actual application. As a rule of thumb the following max clearance values may apply:

- Between rotor and bores or bushings: 0.2 mm
- Between rotor flanks: 0.4 mm

For light duties (low pressure, medium viscosity) even bigger clearances may be acceptable but for low visc./ high pressure duties the limit will be lower.

Also check if there are major scratches on these parts.



When handling liquids that may harm skin use gloves and/or protective clothing.



Oil leakage may make the floor slippery and cause personal injury.

Sectional view

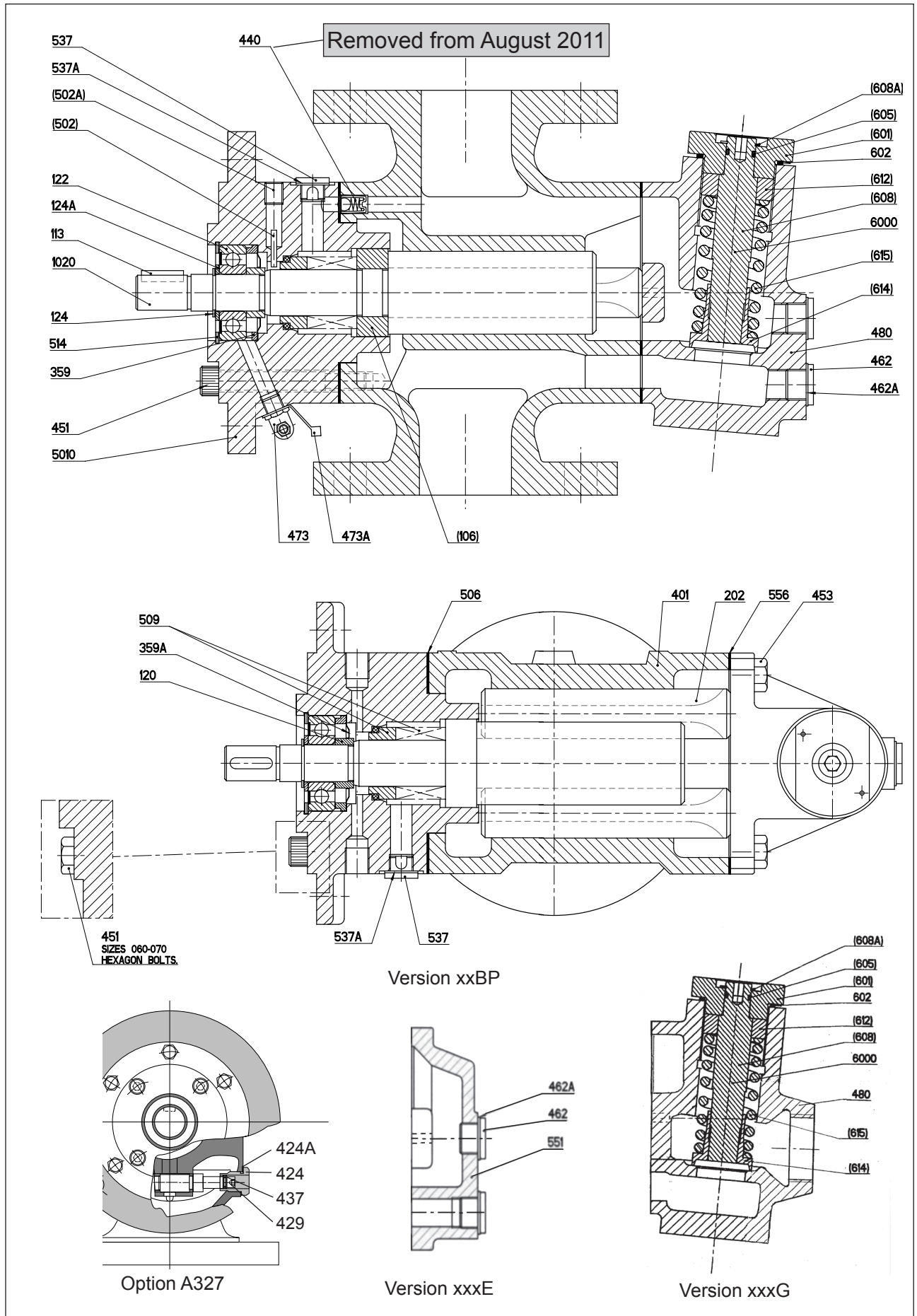

Fig. 5

Dismantling

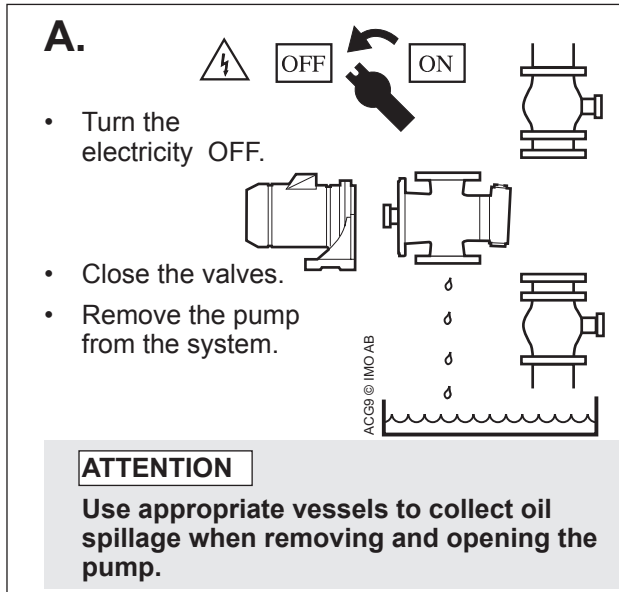

Fig. 6

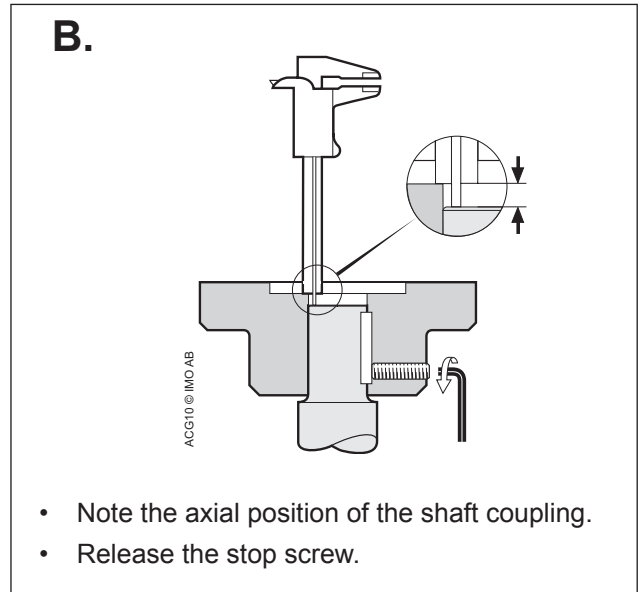

Fig. 7

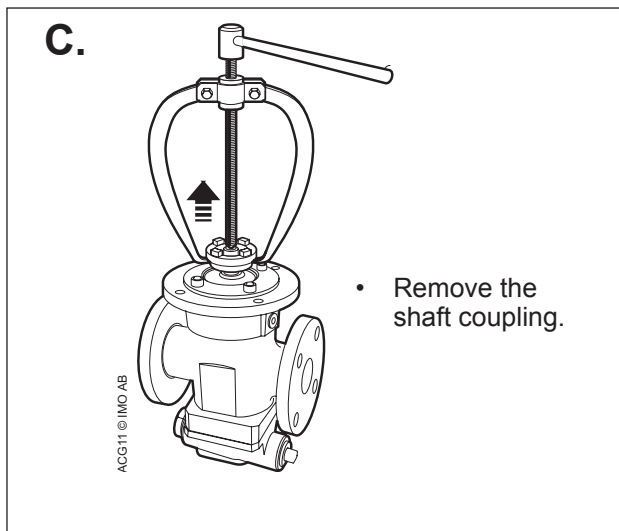

Fig. 8

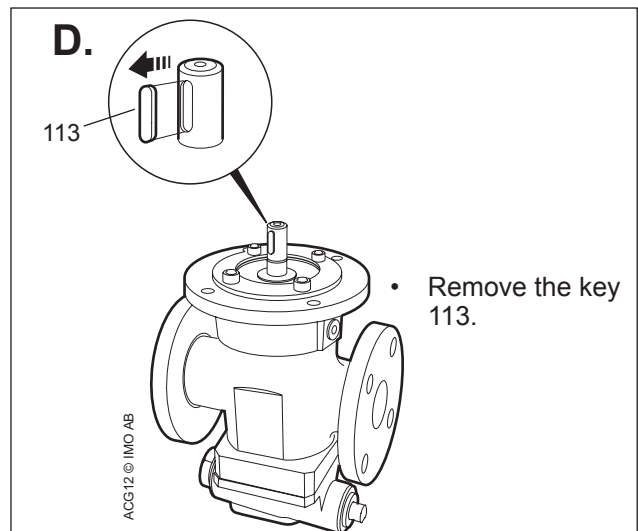

Fig. 9

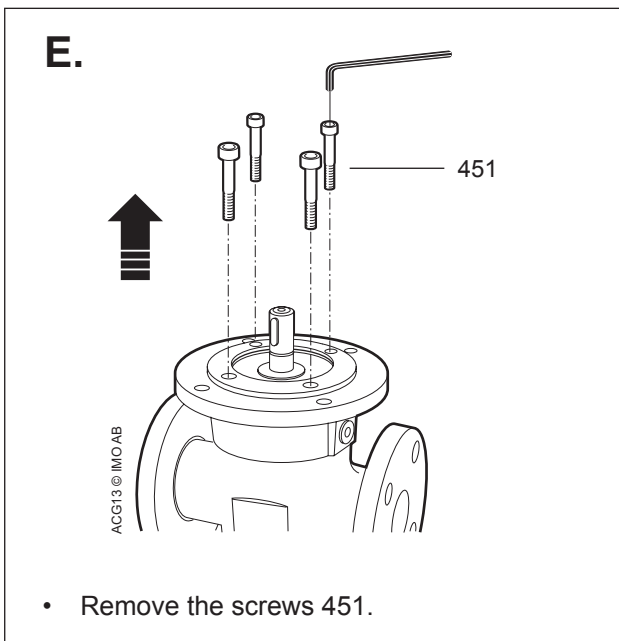

Fig. 10

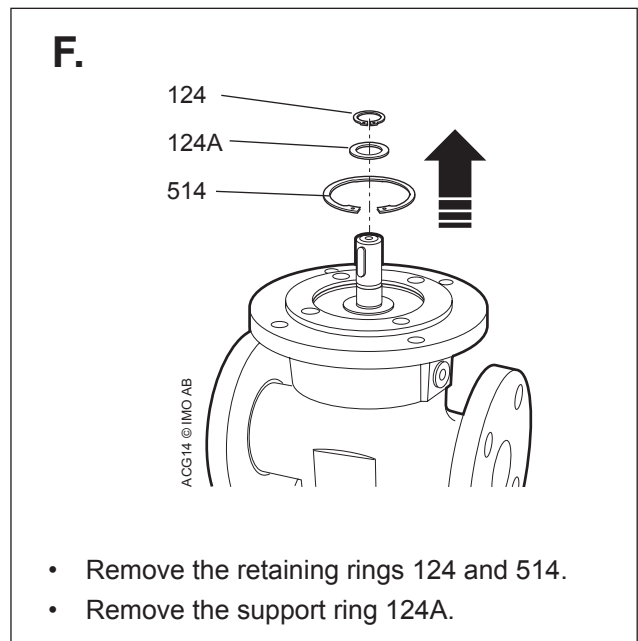

Fig. 11

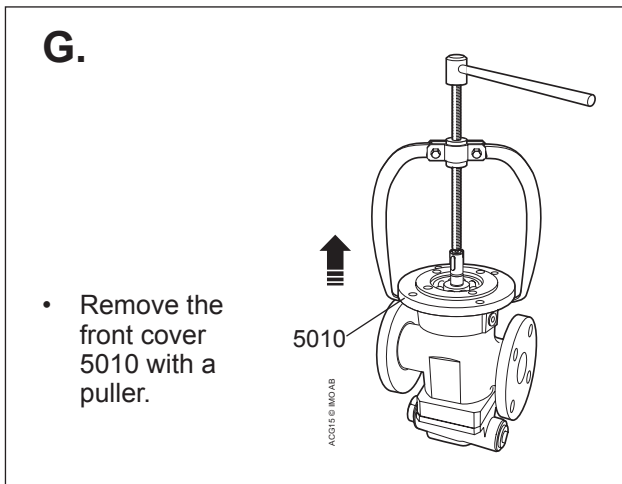

Fig. 12

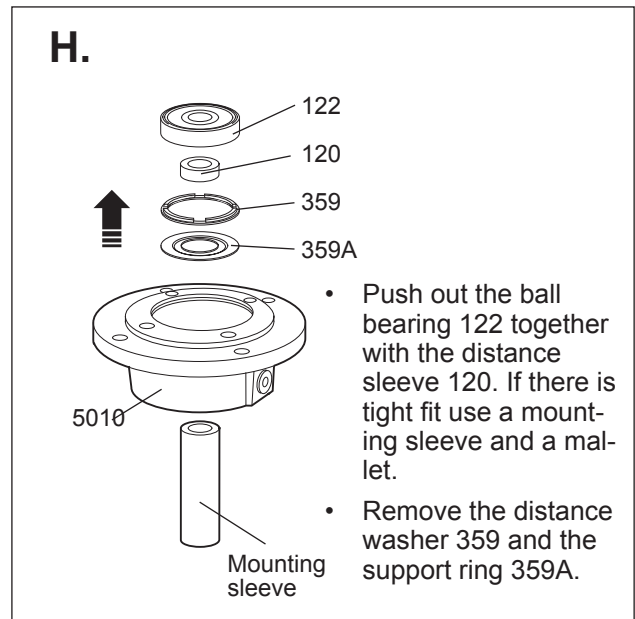

Fig. 13

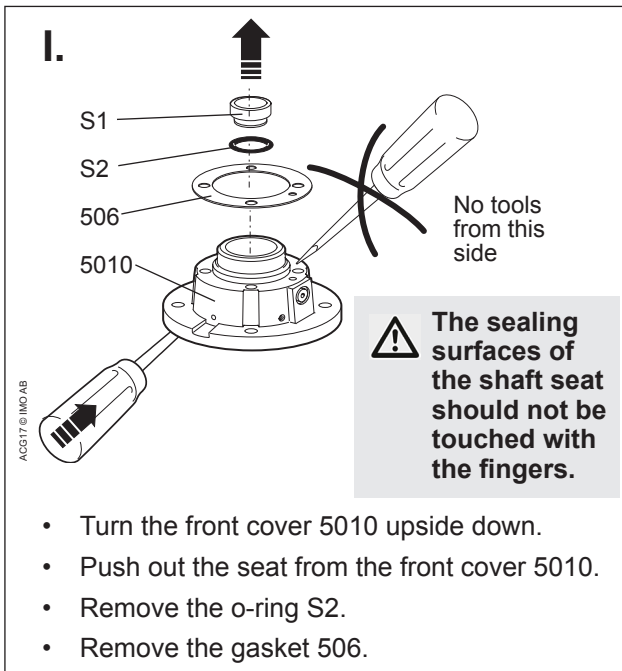

Fig. 14

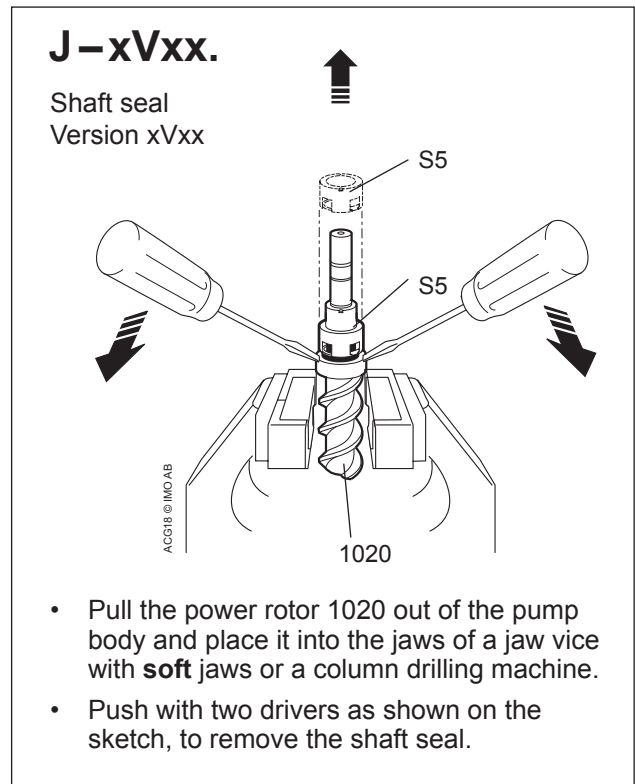

Fig. 15

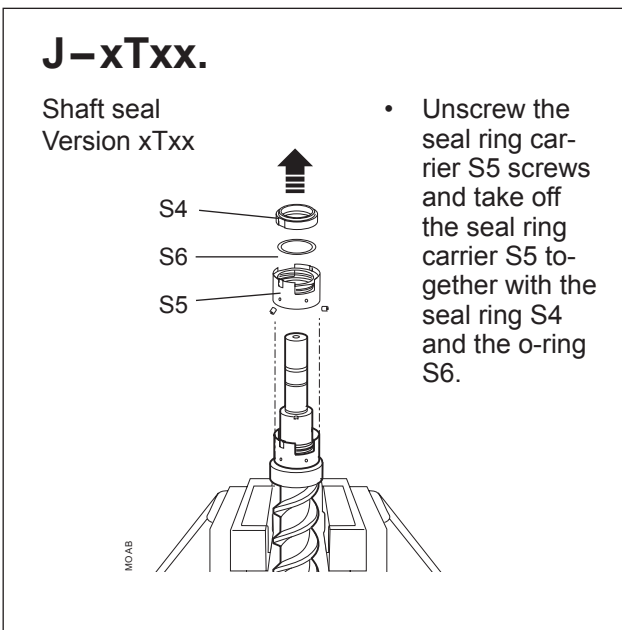

Fig. 16

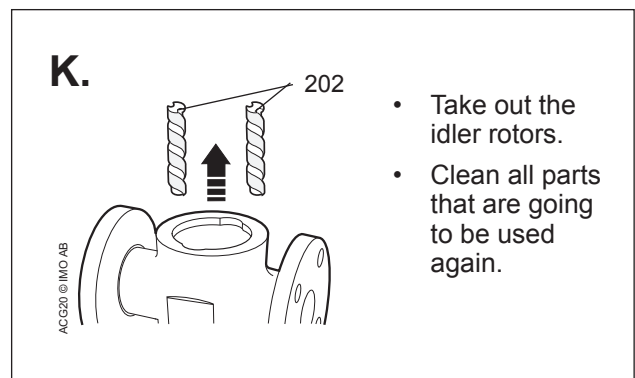

Fig. 17

Reassembly

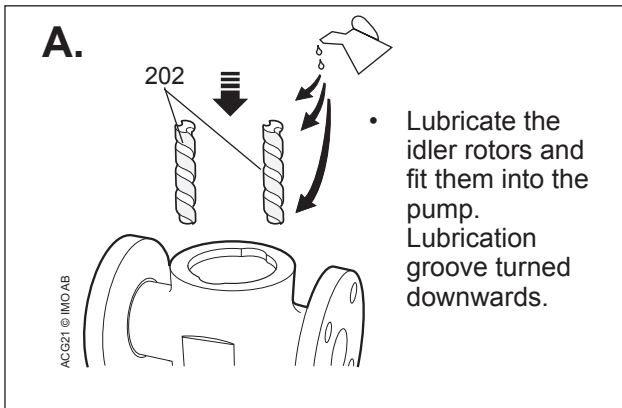

Fig. 18

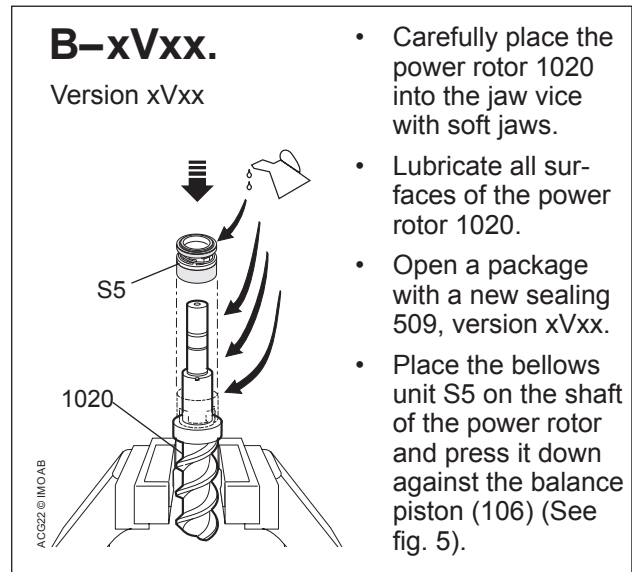

Fig. 19

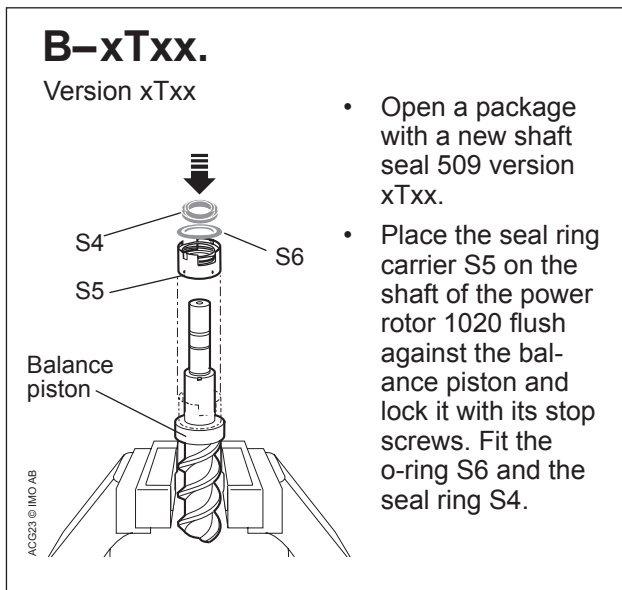

Fig. 20

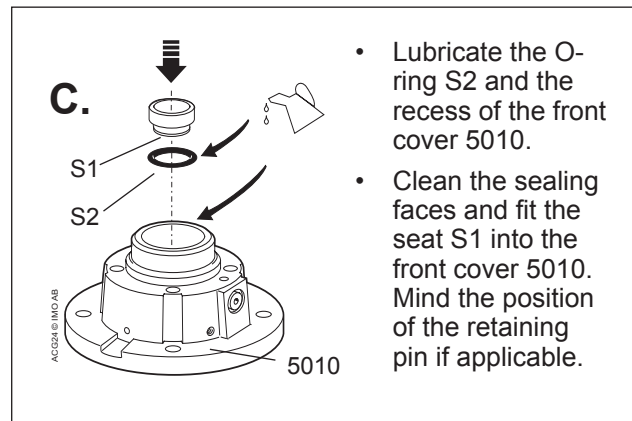

Fig. 21

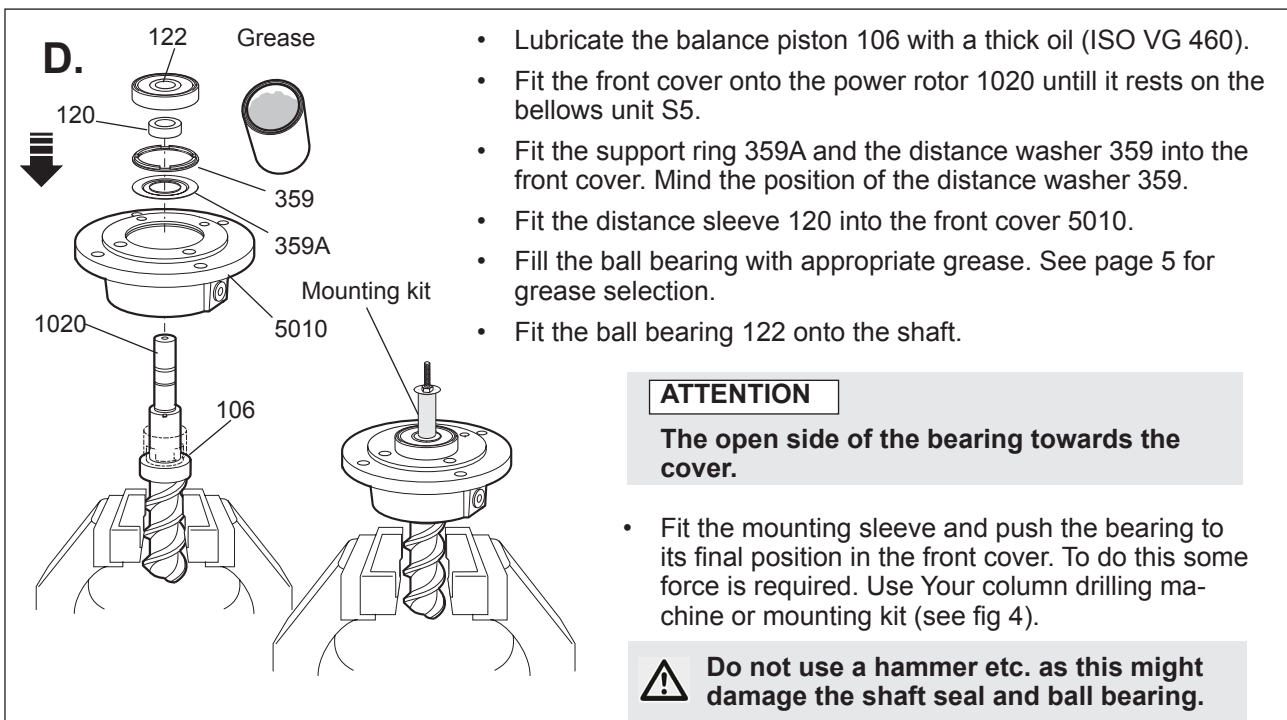
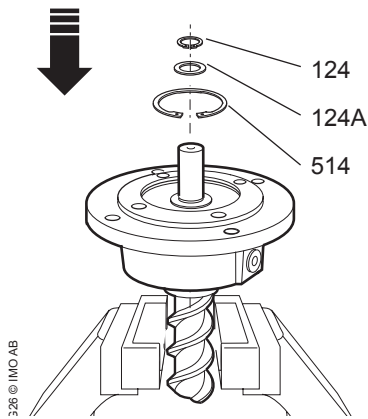

Fig. 22

E.



- Fit the support ring 124A and the retaining ring 124 on the shaft.
- Fit the retaining ring 514 back in place.

Fig. 23

F.

- Fit the key back in position, see fig. 9.
- Fit the shaft coupling back into place (see fig. 7 and 8) with the same method used when fitting the ball bearing.



Do not use a hammer etc. as this might damage the shaft seal and ball bearing.

Fig. 24

G.

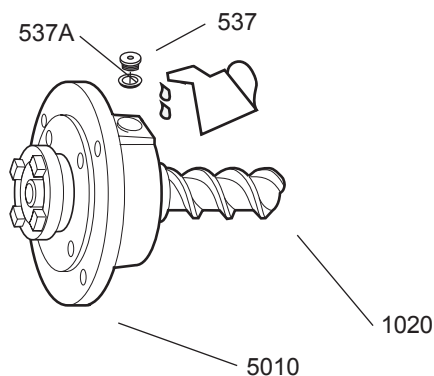

- Remove the plug 537 and washer 537A.
- Hold the rotor unit horizontally with the bore for 537 upwards. Carefully fill the space completely with thin oil (f. ex. ISO VG 46).
- When the oil is flooding, reassemble the above parts in reverse order.
- Slowly turn the shaft a few turns to make sure it moves freely (a certain resistance from the shaft seal is normal but it must be the same during the turns).

Fig. 25

H.

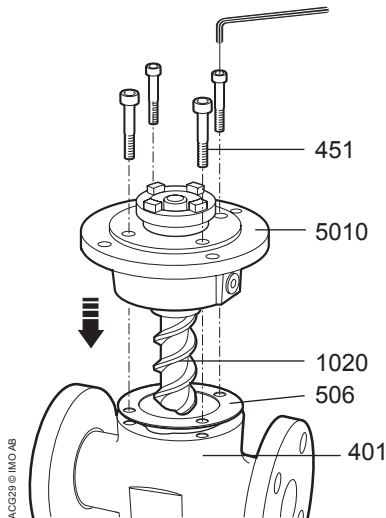

- Place the gasket 506 on the pump body 401.
- Lubricate the power rotor 1020 and fit the front cover 5010 together with the rotor set into the pump body. Mind the position of the tension pin 545.
- Fit the screws 451 and tighten them cross-wise.

Fig. 26

I.

- Put the pump back into the system and proceed according to instructions under "Start-up" in the installation manual.

Fig. 27

Pressure relief valve

Replacement of O-ring 605

- To avoid changing the setting of the valve, use an Allen key to prevent spindle 608 to turn. Unscrew cover 601 and pull up unit 601/608.
- Remove retaining ring 608A and pull the spindle 608 out of cover 601. Replace O-ring 605 and assemble the unit 601/608 in reverse order. Replace retaining ring 608A if necessary and washer 602.
- Fit the unit 601/608 in the valve. Make sure the 608 enters the set screw 612 and use the Allen key to prevent 608 to turn when cover 601 is tightened.

Replacement of Valve Element G070

- Release the spring tension by turning the spindle 608 CCW with an Allen key. Use the Allen key to prevent spindle 608 to turn and unscrew cover 601 but do not remove it yet.
- Remove the set screw 612 by turning the spindle 608 CCW. Pull out the valve piston/spring unit 614/615.
- Fit the valve element in reverse order with a new washer 602. Turn the spindle 608 CW until the set screw leave enough room for cover 601. Use the Allen key to prevent 608 to turn further when cover 601 is tightened.
- Adjust the valve setting according to the "Installation and Start-up Instruction for IMO Low pressure pumps".

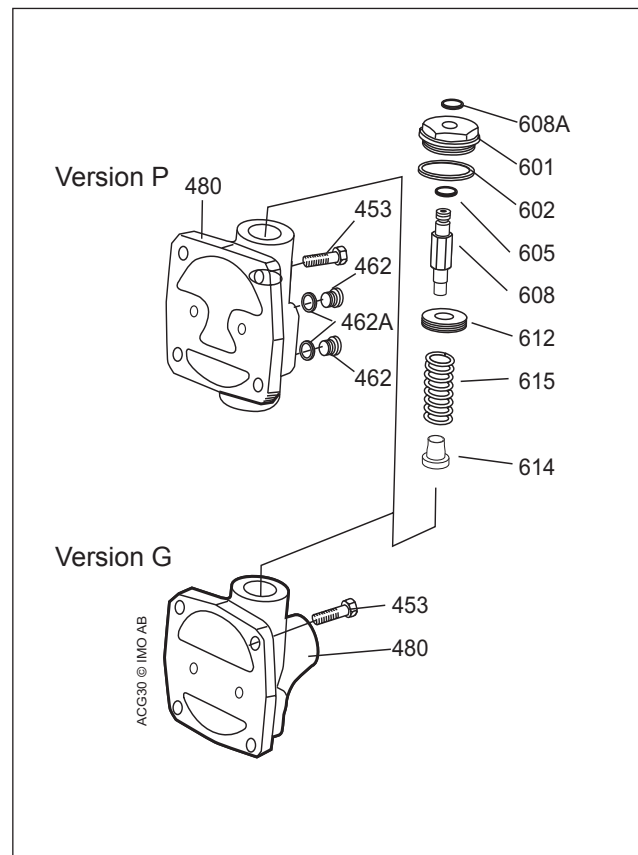

Fig. 28

Adress:

IMO AB
Solna Torg 19, 2tr
171 45 Solna, Sweden